

This is the Revision A version of the [DualMotor1Amp Module](#). The status of this project is [work in progress](#).

DualMotor1Amp Module (Revision A)

Table of Contents

This document is also available as a [PDF](#) document.

- [1. Introduction](#)
- [2. Programming](#)
- [3. Hardware](#)
 - ◆ [3.1 Circuit Schematic](#)
 - ◆ [3.2 Printed Circuit Board](#)
- [4. Software](#)
- [5. Issues](#)

1. Introduction

The DualMotor1Amp Module allows for control of up to two small DC motors via pulse width modulation.

2. Programming

The DualMotor1Amp Module can control up to two motors called 0 and 1 respectively. Each motor has a condition, power mode, direction, and speed. The condition is either on or off (i.e. freewheel.) The two power modes are pulsed and continuous. The two directions are forward and backward. The speed is a number between 0 and 255 inclusive. There is one additional variable associated with each motor called ramp and a few additional variables that are shared between the two motors.

Pulsed mode is standard motor control via pulse width modulation (PWM.) When the speed is 0, no pulses are sent to the motor. When the speed is 255, the motor is full on. When the speed is 128, 50% duty cycle pulses are sent to the motor. The direction bit, controls what direction current is pulsed into the motor.

In continuous mode, power is continuously applied either forward or backward through the motor. In continuous mode, when the speed is 128, 50% duty cycle pulses are sent to the motor, where half the cycle is sends current forward through the motor and the other half is sends current backward through the motor (thereby cancelling out and resulting in a rotational speed of 0.) While continuous mode consumes more power than pulsed mode, it sometimes provides better motor speed control at slow speeds.

The ramp variable is used to slow down the rate at which motor speeds are changed. When the ramp variable is non-zero, it specifies the rate at which motor speed changes (i.e. the speed ramp.) The ramp rate is measured in ticks (1/3 of a bit time at 2400 baud, or 1/7200, or 138 μ S. A ramp rate of 1, means the pulse widths will be changed every 138 μ S. A ramp rate of 100 means the pulse widths will be changed every 100 \times 138 μ S or every 13.8mS. This allows the user to slowly speed up and slow down the motor. Please note, that ramp only applies to speed, changing the motor direction is immediate. (Sorry!)

For safety reasons, you might want the motors to shut off if the controlling program crashes. This is accomplished with a variable called the failsafe delay variable which is shared between both motors. When the failsafe delay variable is set to a non-zero value, it causes another variable called the failsafe counter to be

DualMotor1amp Module (Revision A)

initialized to the same value. Every 256 ticks ($= 256 \times 138\mu\text{S} = 35.5\text{mS}$), the failsafe counter is decremented. If the failsafe counter ever decrements to 0, it immediately turns off both motors without any ramping. Every time a speed command is sent to the DualMotor1Amp Module, the failsafe counter is reinitialed to contain the failsafe delay variable. Thus, by occasionally sending commands that set the speed of either motor, the failsafe counter can be kept non-zero. Alternatively, there is a command that just reinitializes the failsafe counter without affecting the speed. The maximum amount of time between commands that reset the failsafe counter is $255 \times 35.5\text{mS}$ or approximately 9 seconds. If the controlling program crashes, it will stop sending commands to the DualMotor1Amp Module and eventually, the failsafe counter will decrement to zero and stop both motors. There is yet a third variable called the failsafe error counter that is incremented each time a failsafe shut down occurs. The failsafe error counter can be read with yet another command. Lastly, both motors can be restarted by simply sending another command that sets the speed of either motor.

Finally, there is one other variable that is shared between the two motors called the prescaler. The prescaler is 3-bits wide and controls duty cycle width of the pulses are sent to the motor. The table below summarizes the prescaler to duty cycle relationship:

Prescaler	Duty Cycle Width
000	.5 μS
001	1 μS
010	2 μS
011	4 μS
100	8 μS
101	16 μS
110	32 μS
111	64 μS

The DualMotor1Amp commands are summarized in the table below:

Command	Send/Receive	Byte Value								Discussion
		7	6	5	4	3	2	1	0	
Set Quick	Send	0	0	<i>h</i>	<i>h</i>	<i>h</i>	<i>h</i>	<i>d</i>	<i>m</i>	Set motor <i>m</i> speed to <i>hhhh hhhh</i> and direction to <i>d</i> (0=forward, 1=backward).
Set Low	Send	0	1	<i>l</i>	<i>l</i>	<i>l</i>	<i>l</i>	<i>d</i>	<i>m</i>	Set low order 4 bits of motor <i>m</i> speed to <i>ll</i> and direction to <i>d</i> (0=forward, 1=backward).
Set Ramp	Send	1	0	0	0	0	0	0	<i>m</i>	Set the ramp for motor <i>m</i> to <i>rrrrrrrr</i> (00000000=no ramp (default)).
	Send	<i>r</i>	<i>r</i>	<i>r</i>	<i>r</i>	<i>r</i>	<i>r</i>	<i>r</i>	<i>r</i>	
Set Failsafe	Send	1	0	0	0	0	0	1	0	Set the failsafe delay variable to <i>ffffff</i> (00000000=off (default)).
	Send	<i>f</i>	<i>f</i>	<i>f</i>	<i>f</i>	<i>f</i>	<i>f</i>	<i>f</i>	<i>f</i>	
Reset Failsafe	Send	1	0	0	0	0	0	1	1	Reset the failsafe counter to the failsafe delay variable.
Set Speed	Send	1	0	0	0	0	1	<i>d</i>	<i>m</i>	Set motor <i>m</i> to speed <i>sssssss</i> and direction to <i>d</i> .
	Send	<i>s</i>	<i>s</i>	<i>s</i>	<i>s</i>	<i>s</i>	<i>s</i>	<i>s</i>	<i>s</i>	
Set Mode	Send	1	0	0	0	1	0	<i>x</i>	<i>m</i>	Set motor <i>m</i> mode to <i>x</i> (0=pulsed

Dualmotor1amp Module (Revision A)

										(default), 1=continuous).
Set Direction	Send	1	0	0	0	1	1	<i>d</i>	<i>m</i>	Set motor <i>m</i> direction to <i>d</i> (0=forward (default), 1=reverse).
Set Prescaler	Send	1	0	0	1	0	<i>p</i>	<i>p</i>	<i>p</i>	Set prescaler to <i>ppp</i> (000=fast, 111=slow (default)).
Read Failsafe	Send	1	0	0	1	1	0	0	0	Read the return the failsafe delay variable <i>ffffff</i> .
	Receive	<i>f</i>	<i>f</i>	<i>f</i>	<i>f</i>	<i>f</i>	<i>f</i>	<i>f</i>	<i>f</i>	
Read Prescaler	Send	1	0	0	1	1	0	0	1	Read the return the prescaler <i>ppp</i> .
	Receive	0	0	0	0	0	<i>p</i>	<i>p</i>	<i>p</i>	
Read Speed	Send	1	0	0	1	1	0	1	<i>m</i>	Read the return the speed <i>sssssss</i> for motor <i>m</i> .
	Receive	<i>s</i>	<i>s</i>	<i>s</i>	<i>s</i>	<i>s</i>	<i>s</i>	<i>s</i>	<i>s</i>	
Read Mode/Direction	Send	1	0	0	1	1	1	0	<i>m</i>	Read the mode <i>x</i> (0=pulsed, 1=continuous) and direction <i>d</i> (0=forward, 1=reverse) for motor <i>m</i> .
	Receive	0	0	0	0	0	0	<i>x</i>	<i>d</i>	
Read Ramp	Send	1	0	0	1	1	1	1	<i>m</i>	Read and return the ramp <i>rrrrrrrr</i> for motor <i>m</i> .
	Receive	<i>r</i>	<i>r</i>	<i>r</i>	<i>r</i>	<i>r</i>	<i>r</i>	<i>r</i>	<i>r</i>	
Read Failsafe Errors	Send	1	0	1	0	0	0	0	0	Read and return the failsafe error counter <i>eeeeeee</i> . Reset the counter.
	Receive	<i>e</i>	<i>e</i>	<i>e</i>	<i>e</i>	<i>e</i>	<i>e</i>	<i>e</i>	<i>e</i>	
Read Failsafe Counter	Send	1	0	1	0	0	0	0	1	Read and return the failsafe counter <i>ccccccc</i> .
	Receive	<i>c</i>	<i>c</i>	<i>c</i>	<i>c</i>	<i>c</i>	<i>c</i>	<i>c</i>	<i>c</i>	
Read Actual Speed	Send	1	0	1	0	0	0	1	<i>m</i>	Read and return the actual speed for motor <i>m</i>
	Receive	<i>e</i>	<i>e</i>	<i>e</i>	<i>e</i>	<i>e</i>	<i>e</i>	<i>e</i>	<i>e</i>	
On/Off	Send	1	0	1	0	0	1	<i>o</i>	<i>m</i>	Set motor <i>m</i> to condition <i>o</i> (0=off 1=on)
Reset	Send	1	0	1	0	1	0	0	0	Reset the entire motor controller
Shared Commands	Send	1	1	1	1	1	<i>c</i>	<i>c</i>	<i>c</i>	Execute <u>shared command</u> <i>ccc</i> .

On power up, the DualMotor1Amp Module sets all variables to zero. The motor modes default to pulsed forward.

3. Hardware

The hardware consists of a circuit schematic and a printed circuit board.

3.1 Circuit Schematic

The schematic for the DualMotor1Amp Module is shown below:

Dualmotor1amp Module (Revision A)

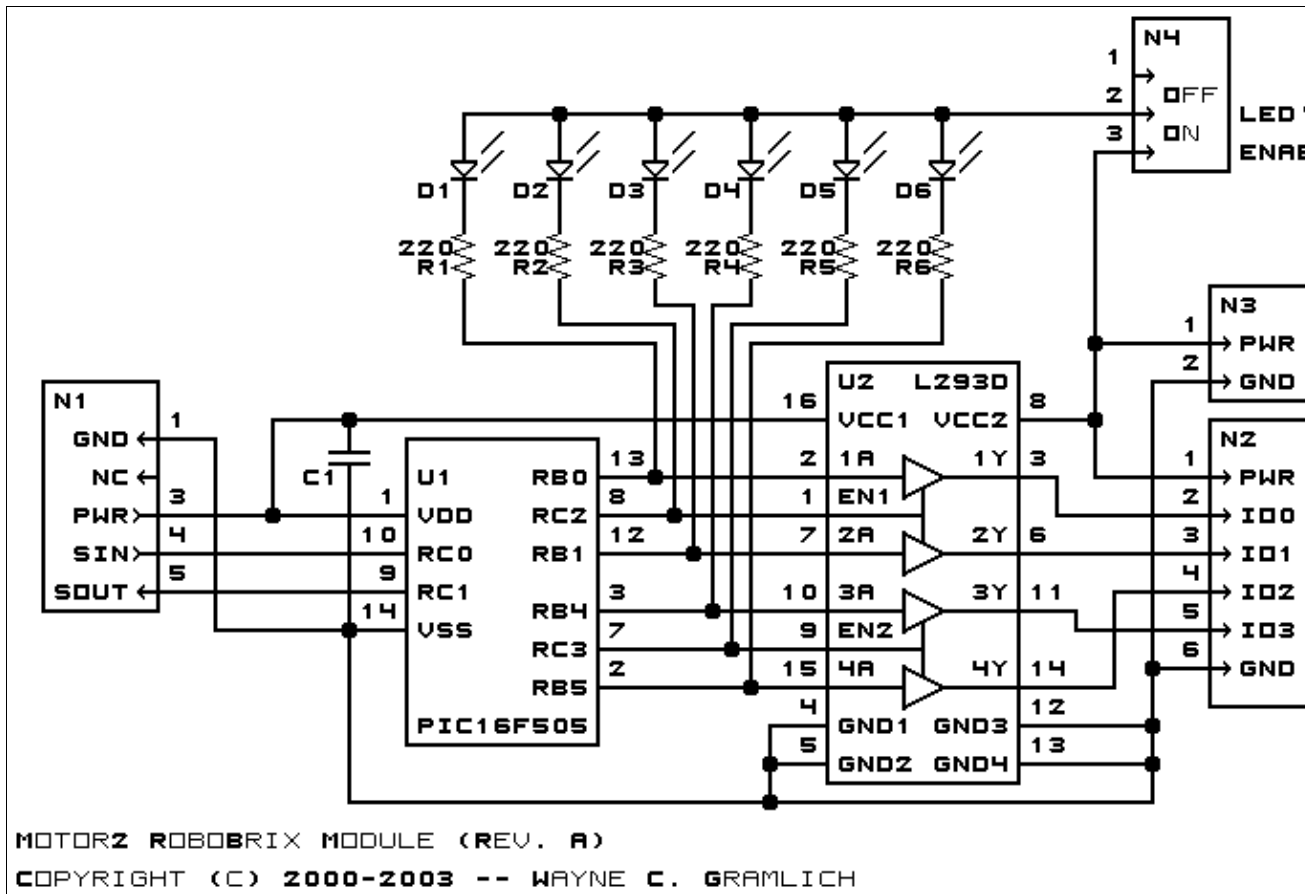

The parts list kept in a separate file -- [dualmotor1amp.ptl](#).

3.2 Printed Circuit Board

The printed circuit files are listed below:

[dualmotor1amp_back.png](#)

The solder side layer.

[dualmotor1amp_front.png](#)

The component side layer.

[dualmotor1amp_artwork.png](#)

The artwork layer.

[dualmotor1amp.gbl](#)

The RS-274X "Gerber" back (solder side) layer.

[dualmotor1amp.gtl](#)

The RS-274X "Gerber" top (component side) layer.

[dualmotor1amp.gal](#)

The RS-274X "Gerber" artwork layer.

[dualmotor1amp.drl](#)

The "Excellon" NC drill file.

[dualmotor1amp.tol](#)

The "Excellon" NC drill rack file.

4. Software

The DualMotor1Amp software is available as one of:

dualmotor1amp.ucl

The μ CL source file.

dualmotor1amp.asm

The resulting human readable PIC assembly file.

dualmotor1amp.lst

The resulting human readable PIC listing file.

dualmotor1amp.hex

The resulting Intel[®] Hex file.

5. Issues

Any fabrication issues are listed here.

Copyright (c) 2000–2004 by Wayne C. Gramlich. All rights reserved.